

SmartSense Sensor Hub User Guide



TABLE OF CONTENTS

Pg 3	Introduction
Pg 4	Sensor Hub Overview
Pg 5	Sensor Hub Setup
Pg 10	Static IP Configuration
Pg 11	Troubleshooting

INTRODUCTION

The SmartSense Sensor Hub is an accessory that integrates with compatible SmartSense gateways. It allows for the collection of data from third party sensors into the SmartSense platform and offers an optional Ethernet connection that can leverage Power over Ethernet (PoE) as a power source for the gateway.

The SmartSense Sensor Hub integrates with Install by SmartSense, which is a mobile application that allows you to easily set up, configure, and check the status of SmartSense assets, gateways, and sensors. Once your hardware is set up, your assets, gateways, sensors, and SmartSense Sensor Hub will sync data to the SmartSense cloud so that real-time data reporting and alarming may be utilized by anyone on your team that has permissions.

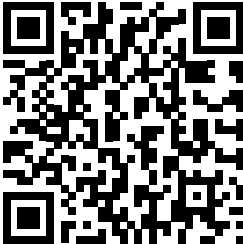

SENSOR HUB OVERVIEW

The SmartSense Sensor Hub is an accessory that connects with the SmartSense BZ Gateway to enable the use of external sensors (i.e. O2, CO2, differential pressure, etc.) and PoE (Power over Ethernet). The Sensor Hub easily connects with existing BZ Gateways.

The SmartSense Sensor Hub has several unique features:

- Enables support for external sensors
- Easy setup via the SmartSense Install app
- Integrates with the BZ Gateway

There are also different LED behaviors that indicate specific activity on the Sensor Hub:

- Solid Green LED = Live Ethernet network detected
- Blinking Green LED = Activity over Ethernet network
- Solid Blue LED = AC power or Power over Ethernet (PoE) connected

Specifications

Product SKU	TM-SENSORHUB
Dimensions	5.7" x 3.6" x 1.7" (145.3mm x 90.8mm x 43.7mm)
Weight	4.3oz (122.2g)
Network Requirements	10/100 Ethernet option
Device Operating Range	5°C to 35°C (40°F to 95°F)
Power Source	100VAC-240VAC, 50Hz/60Hz or PoE IEEE 802.3af
Sensor Type	4-20mA, 24VDC
24VDC Source	100mA max
Maximum Sensors	4 Sensors
Storage Temperature	Short-term and long-term: -20°C to 45°C (-4°F to 113°F)
LED Activity	LED status indicator on device

SENSOR HUB SETUP

To connect the Sensor Hub to the BZ Gateway, slide the BZ Gateway into the Sensor Hub until the two devices lock into place. Secure the BZ Gateway to the back of the Sensor Hub with the screws provided. Once connected, the Sensor Hub can either be mounted or placed on a sturdy surface i.e. table, floor, etc.

Alternatively, you may use mounting pads, brackets, or other mounting hardware to safely secure the Sensor Hub (and BZ Gateway) to a wall. If you choose to mount the Sensor Hub, please ensure that the device is installed securely.

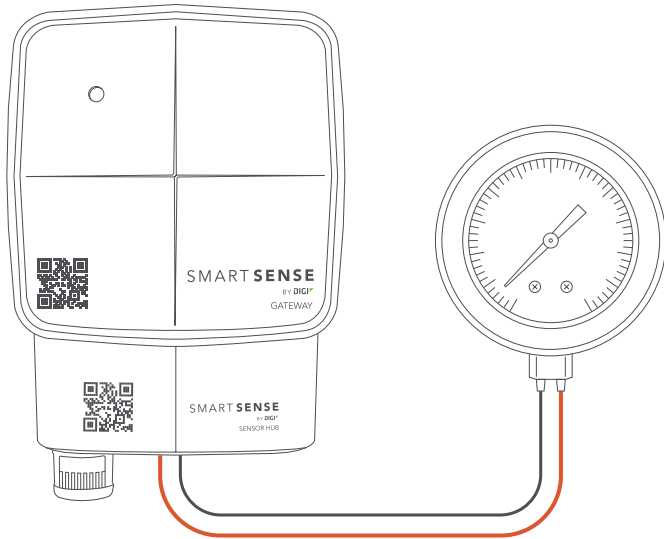

Configuring Sensors with the Sensor Hub

After connecting the Sensor Hub to the BZ Gateway, you will need to attach the sensors to the Sensor Hub. The Sensor Hub supports up to four different sensors at one time. Please use the diagrams below for reference.

Sensor Hub-Powered Single-Sensor Connection

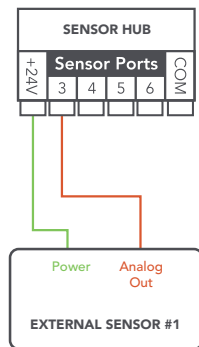

Sensor Hub-Powered Multi-Sensor Connection

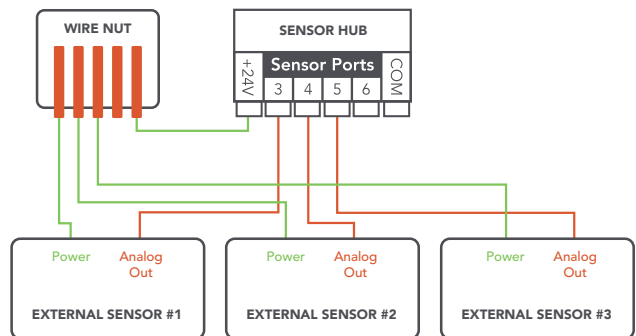

Externally Powered Single-Sensor Connection

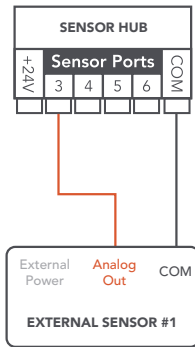

Externally Powered Multi-Sensor Connection

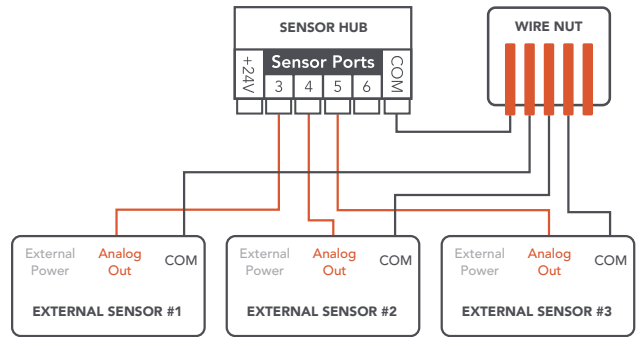

Once the sensors are properly connected to the Sensor Hub, they will need to be configured using the mobile app, **INSTALL BY SMARTSENSE**. If you do not have the app installed on your mobile device, you can download it from the App Store (Apple) or Google Play (Android). Launch the app and log in using your SmartSense credentials.

The screenshot shows the 'Log In' screen of the mobile app. It features a 'Username' input field, a 'Password' input field, and a blue 'Log In' button at the bottom.

Once logged in, you will be directed to the **SITE SELECTION** screen. In the top right corner, click on the **MENU** then select **GATEWAY CONNECTION**. This is where you will begin the configuration for the Sensor Hub.

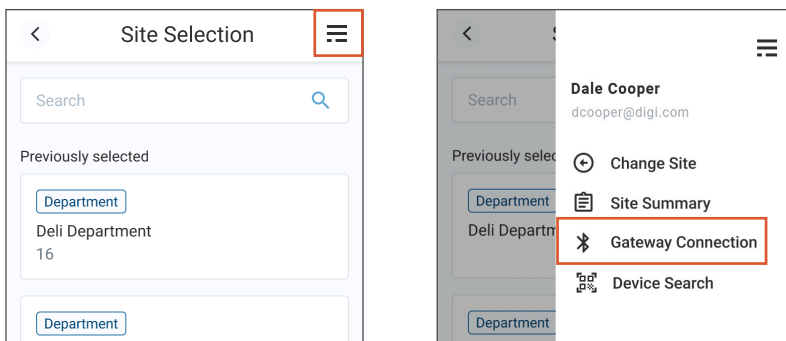

Continued on next page...

The next screen you will see is the **GATEWAY ID** screen. Scan the QR code on the gateway (not to be confused with the Sensor Hub QR code) or manually input the Gateway ID then click **CONNECT** to proceed to the next step.

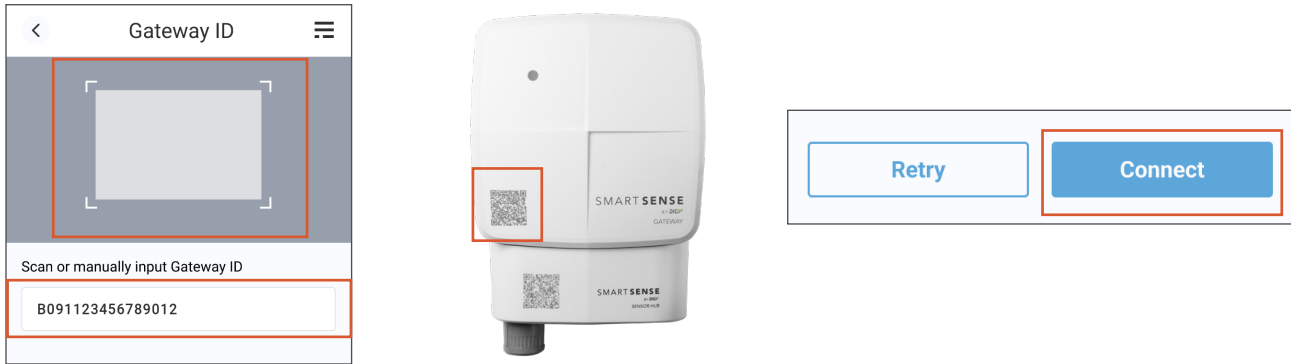

A Bluetooth icon will appear on your screen as the app searches for and attempts to connect to the BZ Gateway via Bluetooth. If the gateway is already powered on, you will need to reset the gateway by holding down the power button for 10-15 seconds. The gateway will display a slow red LED light that will pulse followed by a white LED light. Release the button on the white LED. You should now see the Install app automatically connect to the gateway and display the configuration page.

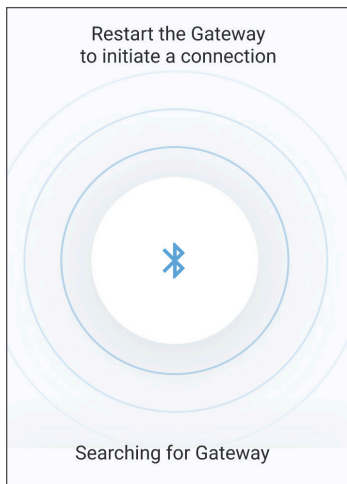

Continued on next page...

If you are unable to connect the gateway, make sure you have entered the correct ID then select the **RETRY** button. Restart the gateway using the steps above. When the gateway successfully pairs, you will automatically be redirected to the **GATEWAY CONFIGURATION** screen and see a blue banner showing that you have network connection.

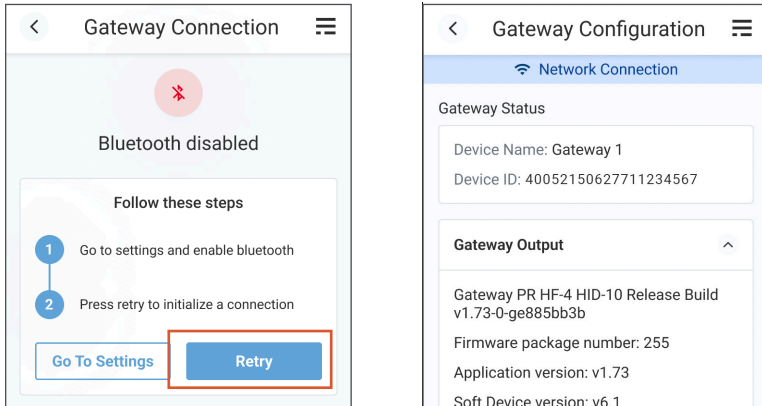

Note: Camera, Bluetooth, and Location permissions will be required for this process. You will be prompted by the Install app to allow these permissions during this process.

Once the BZ Gateway has been successfully connected, you can view the specifications including Gateway Status, Gateway Output, and the Sensor Hub Output. Scroll down to the bottom of the screen to access the ports. There are four available Sensor Hub ports: **PORT 3, PORT 4, PORT 5, and PORT 6.**

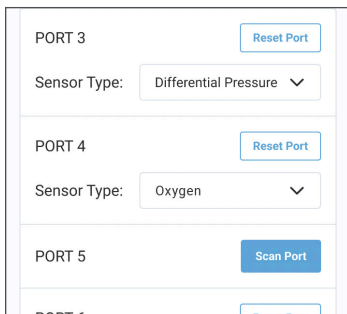

To the right of each port is a blue **SCAN PORT** button. When you click this button, the port will start scanning for a connected sensor. If the sensor is properly connected, select the appropriate **SENSOR TYPE** from the dropdown to assign it.



Continued on next page...

If no sensor is detected, an alert will appear, indicating that a sensor is not connected to that port. Please check the sensor and ensure it is properly connected and functioning. You will be able to scan again by clicking the **RETRY** button.

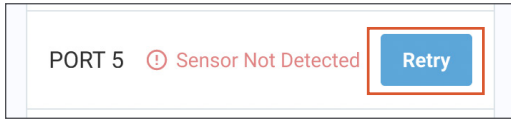

Using Ethernet with the Sensor Hub

The Sensor Hub can also be used to support an Ethernet connection when cellular coverage is not available. Simply connect the Sensor Hub to an active network port and power on the gateway. When connected to a network, the gateway will only attempt to use the Ethernet. The Sensor Hub currently requires the use of Dynamic Host Configuration Protocol (DHCP). Please make sure the device can communicate to the following hostnames to ensure it is available on your network:

- <https://report.myalertlist.com/>
- <https://firmware.ssb.io>
- <https://hw-firmware-logs.devalertlist.com>

Additionally, ensure the device can communicate to the following protocols and ports:

- SSL
- DHCP
- UDP/53
 - IPv4: 8.8.8.8
 - IPv4: 8.8.4.4
 - IPv6: 2001:4860:4860::8888
 - IPv6: 2001:4860:4860::8844
- TCP/4344
- TCP/8031

**The Sensor Hub also supports Power over Ethernet (PoE 802.3af) that can be used in place of the 100VAC-240VAC power supply. The gateway must be 1.77 FW or higher for the Sensor Hub to run Ethernet.*

Continued on next page...

STATIC IP CONFIGURATION

The static IP configuration allows you to apply a custom network setup to a Sensor Hub (minimum requirements are Install app version 1.40.0 and above, Sensor Hub version 2.4.0 and above). On the Install app, you can specify:

- Static IP address
- Default gateway
- Subnet mask/network mask
- DNS servers

The SmartSense Install app and Sensor Hub will perform basic, lightweight validation (e.g., confirming values are formatted correctly and consistently), as pictured below.

**Please be cautious when configuring these network settings, as incorrect values can prevent the Sensor Hub from communicating properly on the network.*

Recommendations

1. Confirm the intended IP address, subnet mask, and gateway with your network administrator before applying changes.
2. Ensure the chosen static IP is unique on the network.
3. Verify the DNS value is accurate.

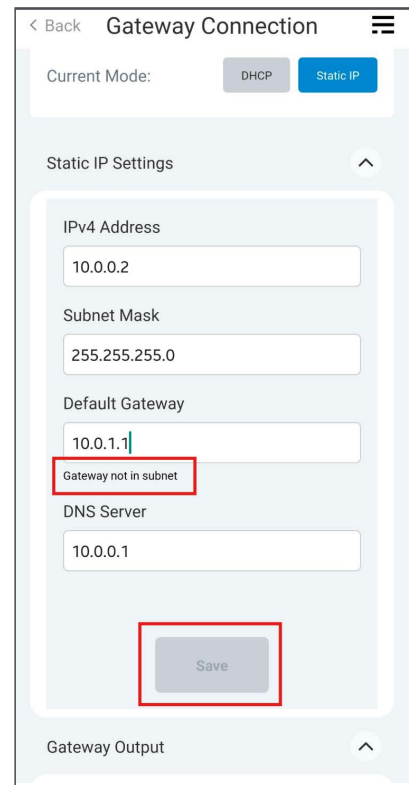
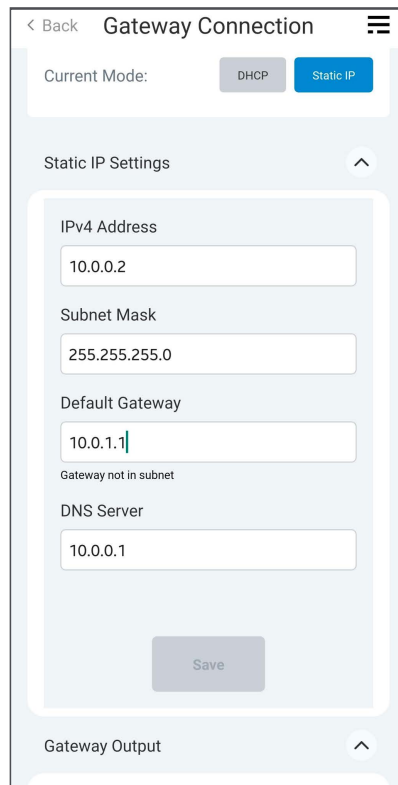
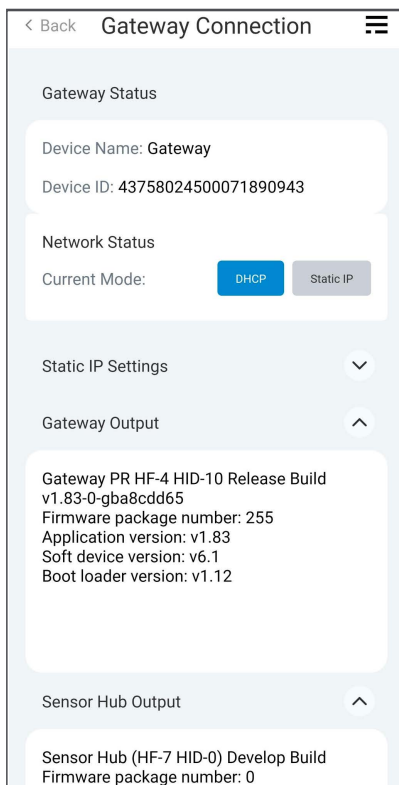

TROUBLESHOOTING

I am unable to connect the Install app to the BZ Gateway when configuring sensors with the Sensor Hub

- If you manually enter the Device ID, ensure the correct Device ID was entered into the Install app
- Ensure Bluetooth is enabled on your mobile device
- Power down the BZ Gateway by holding the power button down until you see a slow, pulsing, red LED light then release the button
- After a few seconds the LED should turn off
- On the Install app, rescan (or manually enter) the Device ID from the BZ Gateway, and click the **CONNECT** button
- While the app is attempting to connect to the BZ Gateway, power up the BZ Gateway by holding the power button for a few seconds (until you see a white LED), then release
- The Install app should now successfully connect to the BZ Gateway

There are no sensors available when attempting to configure ports with the Install app

- Check the wire connections on both the sensor and the Sensor Hub to ensure that the wires are securely connected
- Verify that the sensor is active and powered on (only active sensors will appear)
- Verify that the sensor's wires are properly configured (use the wiring diagram on page 5 for reference)